

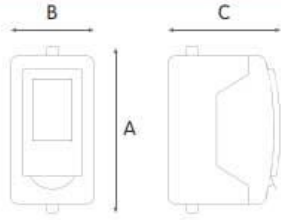

KIT AUTO

WORKING CONDITIONS

Max working pressure	10 bar (145 psi)
Min differential pressure	0,15 bar (2 psi)
Max working temperature	45°C (113°F)
Min working temperature	4°C (39°F)
Applicable fluid	water
pH range	6,5 - 8,5



KIT AUTO

FOR SELF-CLEANING FILTERS

CODE MODEL

RE7120024 KIT AUTO

DIGITAL CONTROL PANEL DIMENSIONS mm

A	B	C
195	80	100



TECHNICAL FEATURES

ELECTROVALVE

CONSTRUCTIONS

Body and cover: brass CW 617 N
 Fitting: stainless steel AISI 304
 Plunger and core: stainless steel AISI 304
 Springs: stainless steel AISI 302
 Diaphragm: EPDM

FEATURES

Junction	1/2"
Conduit	12 mm
Max discharge flow rate	2,5 m ³ /h

SPARE PARTS LIST

1. Coil fixing nut
2. Coil
3. Plunger
4. Armature tube with core
5. Diaphragm
6. Spring

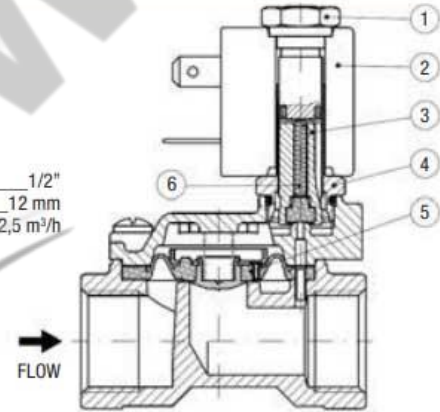

SELF-CLEANING
FILTERS

DIGITAL CONTROL PANEL

AUTOMATIC CONTROL

Minimum programmable period for back-wash	2 h
Maximum programmable period for back-wash	99 h
Minimum flushing time	5 s
Maximum flushing time	99 s

Power Supply	AC 50/60 Hz 230 V
Plug	CEE 7/4 (Shuko)
Power supply Cable Length	1,8 m
Coil supply Cable Length	1 m

MANUAL CONTROL

Manual actuation of the electrovalve every 60 s

BOX

Protection degree: IP65
 Dimensions: 150x100x80 mm

COIL

Power Supply	AC 50/60 Hz 24V
Insulation class	F
Protection class with connector fixed	IP65